

## LIGHT AND AIR CONTROL PLUS REMOTE CONTROL

Model 40011 / Item # 0374118

### User Guide

#### IMPORTANT SAFETY INSTRUCTIONS

1. Read and keep this instruction sheet for future reference.
2. Please note that all fixed wiring appliances should be installed by a qualified electrician.
3. The supply to the receiver should be connected on its own circuit.
4. Switch off the power at the circuit breaker before working on receiver or ceiling fan.
5. This unit is to be used for the control of a ceiling fan and its electrical source must be AC 110/120V, 60Hz.
6. Do not install in damp location or immerse into water. For indoor use only.
7. Do not use this remote with fans that have pre-installed remote controls.

**CAUTION:** To reduce the risk of fire or injury, do not use this product in conjunction with any variable (rheostat) wall control.

#### RECEIVER INSTALLATION INSTRUCTIONS

**NOTE:** This remote can work with a variety of hugger fan types, however, there is typically very little space in the hanger bracket area to install a receiver. Therefore, we do not recommend using this remote with hugger type or 5 speed ceiling fans.

1. After switching power off @ circuit breaker, remove ceiling fan canopy from the mounting bracket. Disconnect existing wiring between ceiling fan and supply at electrical junction box.
2. Slide the receiver into the mounting bracket per FIG.1 being careful not to pinch the antenna wire.
3. The receiver will be inserted between the down rod and the mounting bracket.
4. Make wiring connections per FIG. 2.
5. Push all connected wires back into the junction box and reinstall the canopy onto the mounting bracket.
6. Manually set fan speed control to HIGH and set light to ON using the pull chains.

**NOTE:** For the remote to function properly, the fan must be on HIGH speed and lights must be ON to use.

**CAUTION:** Incorrect wire connection can damage this receiver and could cause injury or fire.

#### ACTIVATING THE LEARNING PROCESS (SMART SYNC)

**NOTE:** This remote is pre-programmed from the factory and should work right out of the box once the battery is installed. Should, for any reason, re-programming be needed please follow the learning process as follows:

1. After installation is complete and power is turned on, remove the battery cover on transmitter. Insert batteries (1x 12V, included).
- NOTE:** Do not mix old and new batteries, alkaline, standard (carbon-zinc) or rechargeable (nickel-cadmium) batteries.
2. Use a small screwdriver or ballpoint pen to press and hold the "LEARN" key, located in the battery compartment (see FIG. 3.), for 3 seconds. Fan will turn on at high speed and light (if installed) blinks 3 times. This confirms that the SMART SYNC setting is active. You now have 30 seconds to press the LEARN key. Tap the FAN OFF button to turn off the fan.
  3. If user cannot finish the setting within the 30 seconds time frame the main power must be turned off and re-started again. This will reset the unit. Repeat step 2 until the LEARNING feature is activated as indicated.

**NOTE:** User must press "LEARN" key **within 30 seconds** after main power is turned on. It is not necessary to redo the LEARNING setting if just replacing batteries.

#### DIMMER ON/OFF SETTING (D/O SWITCH)

Slide the D/O switch, located in the battery compartment (See FIG. 3), to match the bulb

type in your fan. "D" is for incandescent bulbs and "O" indicates compact fluorescent bulbs (CFL). Use a small screwdriver or ballpoint pen to slide firmly left or right.

**CAUTION:** Incorrect bulb setting can damage the receiver.

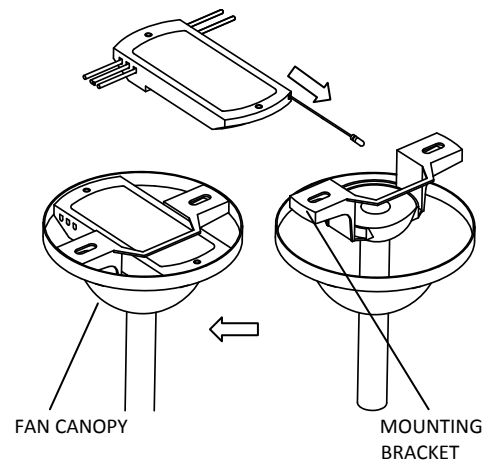

**FIG 1**  
INSERTING RECEIVER INTO CANOPY ASSEMBLY

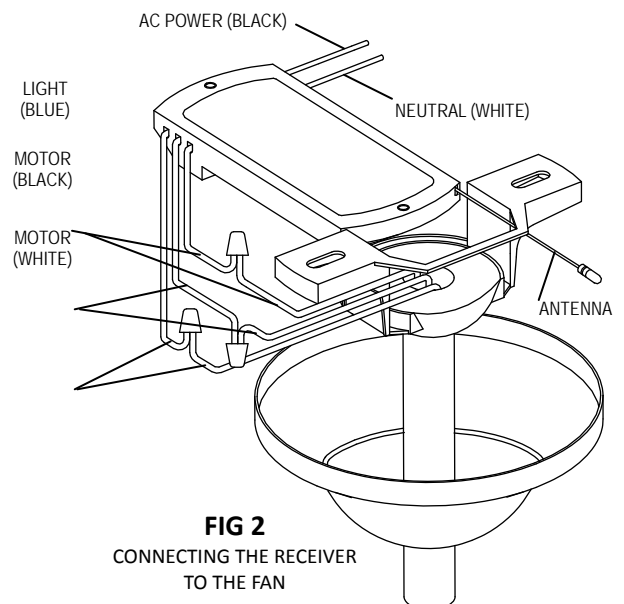

**FIG 2**  
CONNECTING THE RECEIVER TO THE FAN

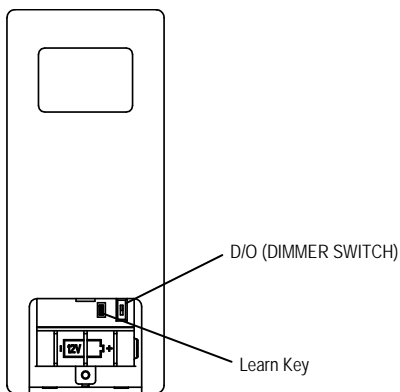

**FIG 3**

REAR VIEW OF TRANSMITTER – SHOWN WITH BATTERY COVER REMOVED

## TRANSMITTER OPERATION (FIG.4)

**High / Medium / Low Speed** – Tap lightly to turn the fan on at high, medium or low speed respectively.

**Fan Off** – Tap lightly to turn the fan off.

**Light** – Tap lightly to turn light on or off. Hold down for 2 seconds to cycle through dimmer setting. The light button has an auto resume feature so the light will re-activate at the same brightness as the last time it was turned off.

**NOTE:** The dimmer function does not work with CFL bulbs.

**Walk Away Light Delay** – Tap once - the light and fan turn off after 1 minute. Light on the fan blinks once to confirm function is active. Press any button to cancel function.

**D/O** – Set the light for use with incandescent bulbs or compact fluorescent bulbs (CFL).

**LEARN** – Synchronizes transmitter and receiver signals.

**NOTE:** Factory default setting is CFL.

## INSTALLING THE WALL MOUNT BRACKET

1. Locate wall mount in a convenient location
2. Use two screws (included) and wall anchors to install wall mount bracket as shown in FIG. 5. (Tools required for assembly: Philips screwdriver, not included)

## TROUBLE SHOOTING

- Review receiver wiring – is it wired correctly and receiving power?
- Is the fan speed control on HI and light switch in the ON position?
- Are all batteries new and fully charged?
- Learning process between fan and transmitter may not have been successful – see step 2 under activating the learning process
- Won't operate at a distance – make sure antenna wire is visible and not obstructed

## WARRANTY

This product is warranted to be free from defects in material and workmanship, under normal use and maintenance, for a period of (1) year from the date of purchase. This warranty shall not cover any removal or reinstallation costs, and shall not apply to: (i) cosmetic damage, such as scratches, nicks and dents; (ii) any alteration or improper repair, maintenance, handling, or installation; (iii) the combination of the product with other systems or components; (iv) consumable parts, such as batteries, including any deterioration or damage to the product caused by the use of faulty batteries; (v) damage caused by accident, abuse, misuse, water, flood, fire, or other acts of nature or external causes; (vi) damage caused by service performed by anyone who is not an authorized service provider; or (vii) damage to a product that has been modified or altered. Your sole and exclusive remedy for a breach of warranty shall be replacement of the product. Alternatively, you may return your product to the retailer from which you made your purchase in accordance with applicable return policies.

THE WARRANTIES AND REMEDIES CONTAINED HEREIN ARE EXCLUSIVE AND IN LIEU OF ALL OTHER WARRANTIES WHETHER EXPRESS, IMPLIED, OR STATUTORY, INCLUDING ANY LIABILITY ARISING UNDER ANY WARRANTY OF MERCHANTABILITY OR FITNESS FOR A PARTICULAR PURPOSE, STATUTORY OR OTHERWISE. THIS WARRANTY GIVES YOU SPECIFIC LEGAL RIGHTS, WHICH MAY VARY FROM STATE TO STATE. IN NO EVENT SHALL ANY PARTY BE LIABLE FOR ANY INCIDENTAL, SPECIAL, INDIRECT, OR CONSEQUENTIAL DAMAGES, WHETHER RESULTING FROM THE USE, MISUSE, OR INABILITY TO USE THIS PRODUCT OR FROM DEFECTS IN THE PRODUCT. SOME STATES DO NOT ALLOW THE EXCLUSION OR LIMITATION OF INCIDENTAL OR CONSEQUENTIAL DAMAGES, SO THE ABOVE LIMITATIONS MAY NOT APPLY TO YOU.

To obtain warranty service, please call the customer service number below. One of our customer service representatives will assist you in determining whether you have a warranty claim and, if so, how to return your product. If you return your product for a warranty claim, please securely pack your product and include a copy of the original sales receipt, which is required as the proof of purchase for all warranty claims. You shall be responsible for shipment and assume all costs and risks associated with any product return.

The Honeywell Trademark is used under license from Honeywell International Inc. Honeywell International Inc. makes no representations or warranties with respect to this product. This product is manufactured for:

Hong Kong China Electric Appliance Manufacture Co., Ltd.  
3050 Forest Hill Irene Rd, Ste 103  
Germantown, TN 38138  
1-877-580-4359

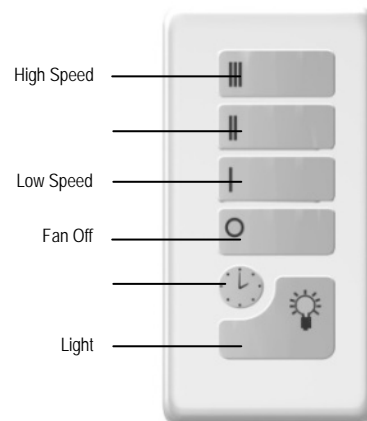

**FIG 4**

TRANSMITTER OPERATION

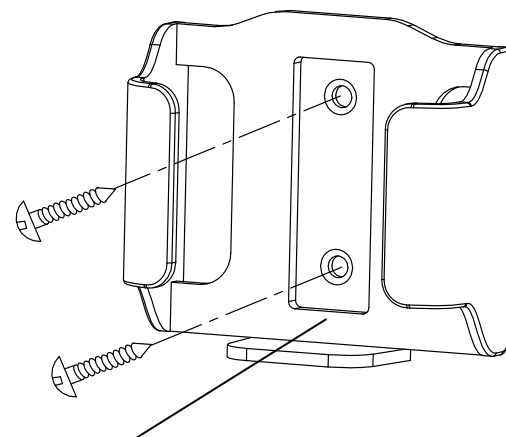

**FIG 5**  
WALL MOUNT BRACKET

---

**FEDERAL COMMUNICATIONS COMMISSION INTERFERENCE  
STATEMENT**

This equipment has been tested and found to comply with the limits for a Class B digital device, pursuant to Part 15 of the FCC Rules. These limits are designed to provide reasonable protection against harmful interference in a residential installation. This equipment generates, uses and can radiate radio frequency energy and, if not installed and used in accordance with the instructions, may cause harmful interference to radio communications. However, there is no guarantee that interference will not occur in a particular installation. If this equipment does cause harmful interference to radio or television reception, which can be determined by turning the equipment off and on, the user is encouraged to try to correct the interference by one or more of the following measures: Reorient or relocate the receiving antenna. Increase the separation between the equipment and receiver. Connect the equipment into an outlet on a circuit different from that to which the receiver is connected. --Consult the dealer or an experienced radio/TV technician for help.

**CAUTION:**

**To assure continued FCC compliance:**

Any changes or modifications not expressly approved by the grantee of this device could void the user's authority to operate the equipment.

**FCC ID : KUJCE10003**

This device complies with Part 15 of the FCC Rules. Operation is subject to the following two conditions: (1) This device may not cause harmful interference, and (2) this device must accept any interference received, including interference that may cause undesired operation.



***One Year Limited Warranty***

If you have questions regarding this product, before returning to your retailer, call our customer service department toll free at **1-877-580-4359**

**Printed in China**